

8

7

6

5

4

3

2

1

REVISIONS				
ZONE	REV.	DESCRIPTION	DATE	APPROVED

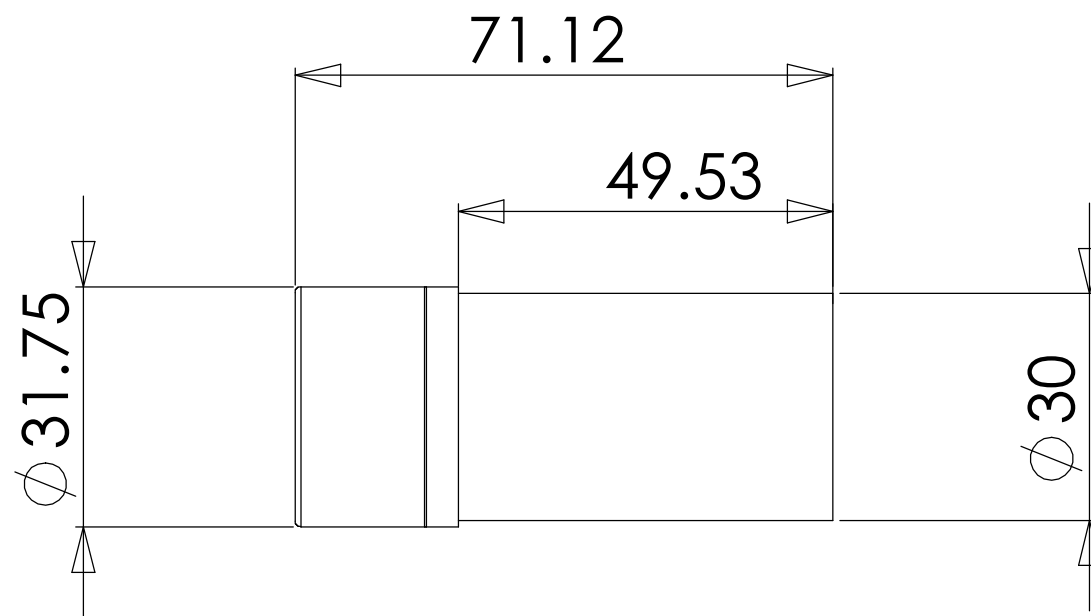
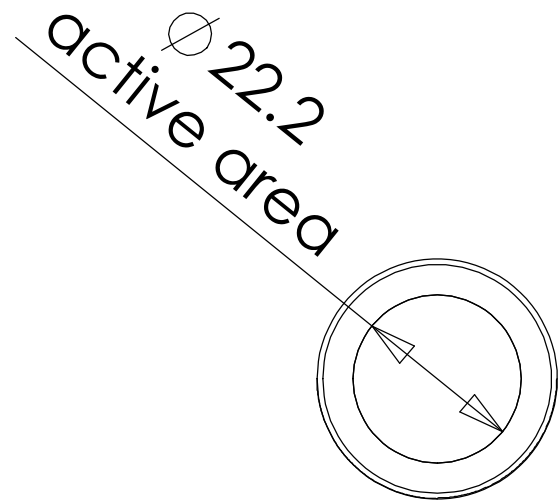
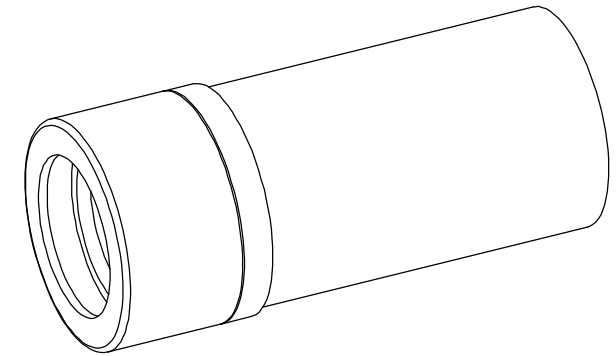

**PROPRIETARY AND CONFIDENTIAL**  
 THE INFORMATION CONTAINED IN THIS DRAWING IS THE SOLE PROPERTY OF SmartVisionLights. ANY REPRODUCTION IN PART OR AS A WHOLE WITHOUT THE WRITTEN PERMISSION OF SmartVisionLights IS PROHIBITED.

UNLESS OTHERWISE SPECIFIED:		DATE	NAME	SW30  SmartVisionLights.Com  matt@smartvisionlights.com		
DIMENSIONS ARE IN MM		DRAWN BY	9/28/2009			
TOLERANCES:		CHECKED				
FRACTIONAL ±1-64		ENG APPR.				
ANGULAR: MACH ±.25° BEND ±3°		MFG APPR.				
TWO PLACE DECIMAL ±.10 mm		Q.A.		SIZE	DWG. Name	REV
THREE PLACE DECIMAL ±.01 mm		COMMENTS:		<b>B</b>	SW30	
INTERPRET GEOMETRIC TOLERANCING PER:				SCALE: 1:1	SHEET 1 OF 1	
MATERIAL				Path: Z:\2009\SVL\temp\		
FINISH						
NEXT ASSY	USED ON					
APPLICATION						

8

7

6

5

4

Path: Z:\2009\SVL\temp\