

REVISIONS

ZONE	REV.	DESCRIPTION	DATE	APPROVED

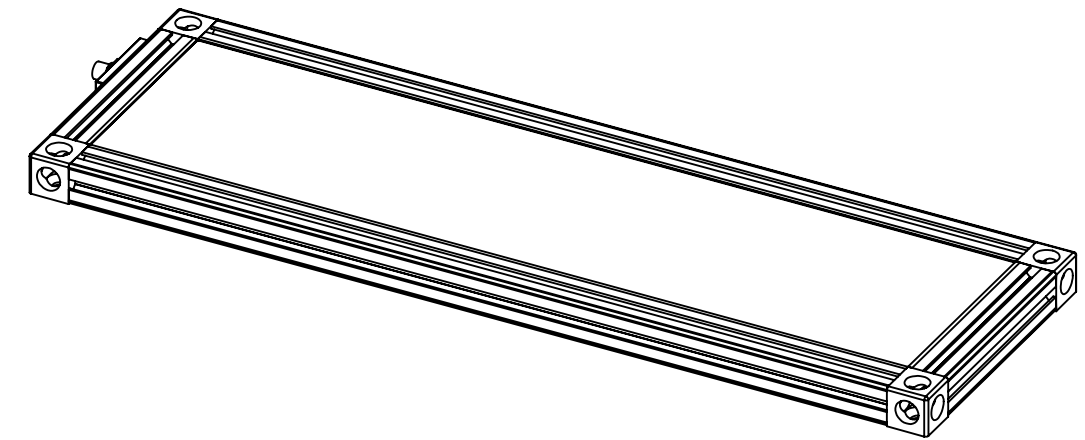

typ. \varnothing 9 THRU ALL
 \varnothing 17.3 ∇ 24

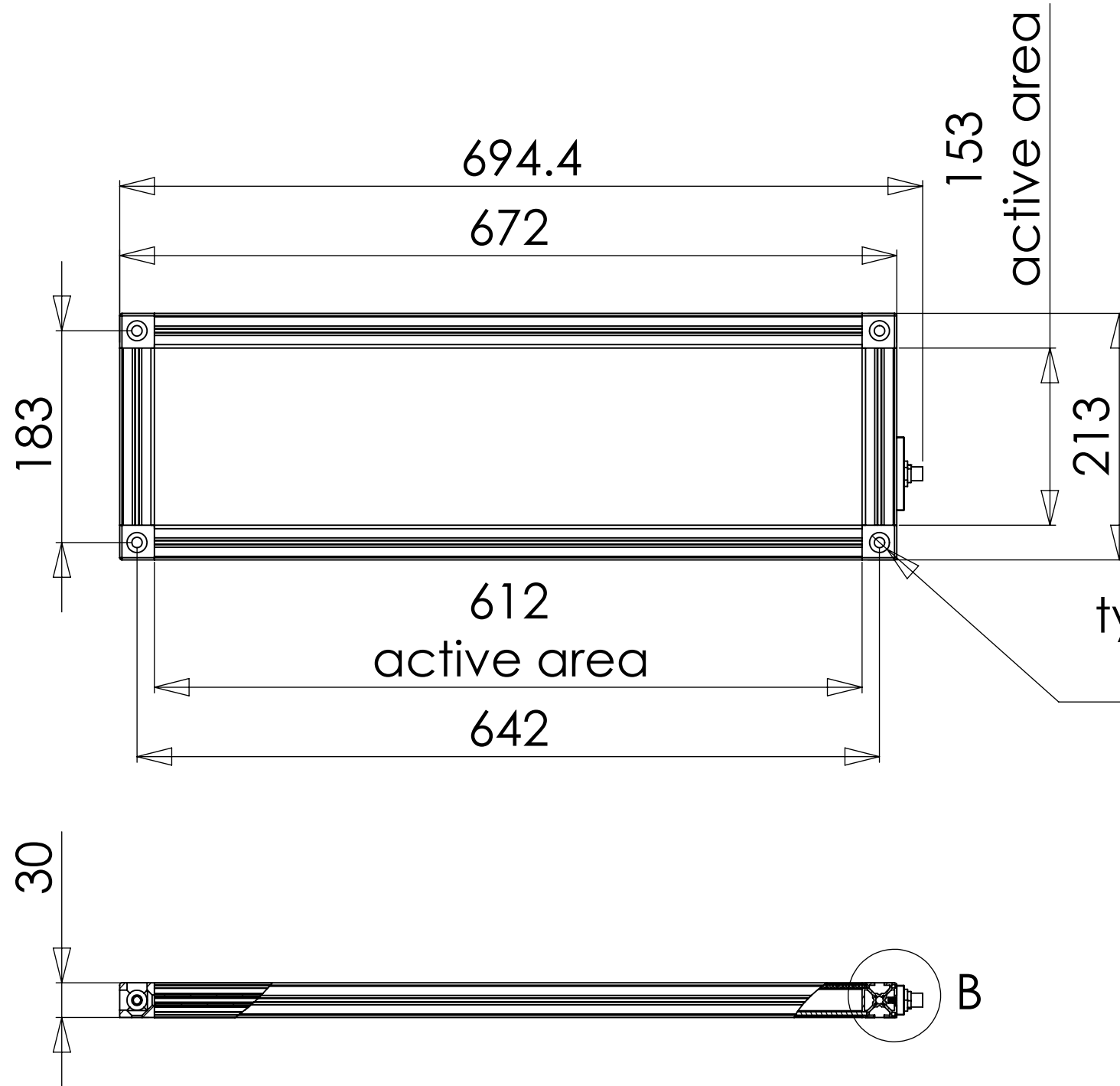
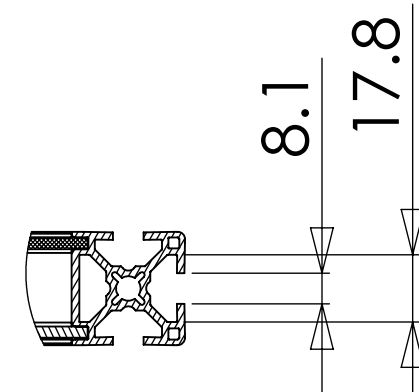

DETAIL B
 SCALE 1 : 2

PROPRIETARY AND CONFIDENTIAL
 THE INFORMATION CONTAINED IN THIS DRAWING IS THE SOLE PROPERTY OF SmartVisionLights. ANY REPRODUCTION IN PART OR AS A WHOLE WITHOUT THE WRITTEN PERMISSION OF SmartVisionLights IS PROHIBITED.

UNLESS OTHERWISE SPECIFIED:		DATE	NAME	SOBL-600X150
DIMENSIONS ARE IN MM		12/7/2010		
TOLERANCES:		DRAWN BY		SmartVisionLights.Com
FRACTIONAL \pm 1-64		CHECKED		
ANGULAR: MACH \pm .25° BEND \pm 3°		ENG APPR.		matt@smartvisionlights.com
TWO PLACE DECIMAL \pm .10 mm		MFG APPR.		
THREE PLACE DECIMAL \pm .01 mm		Q.A.		SIZE B DWG. Name SOBL-600X150 REV
INTERPRET GEOMETRIC TOLERANCING PER:		COMMENTS:		
MATERIAL	FINISH			SCALE: 1:5 SHEET 1 OF 1
NEXT ASSY	USED ON			
APPLICATION				