

REVISIONS				
ZONE	REV.	DESCRIPTION	DATE	APPROVED

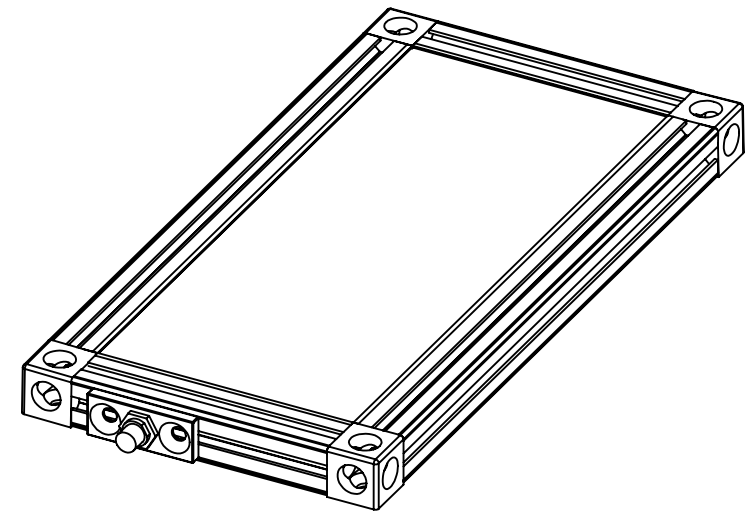

typ.  $\varnothing$  9 THRU ALL  
 $\square$   $\varnothing$  17.30  $\nabla$  24

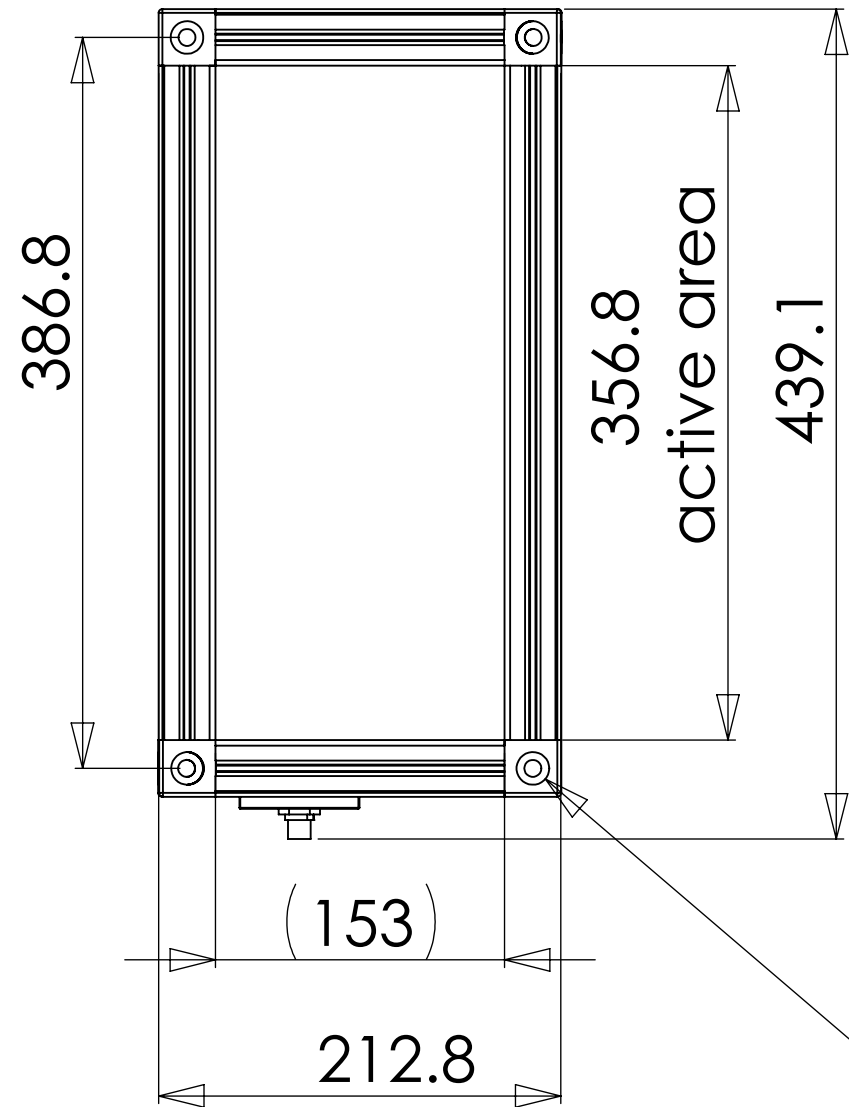
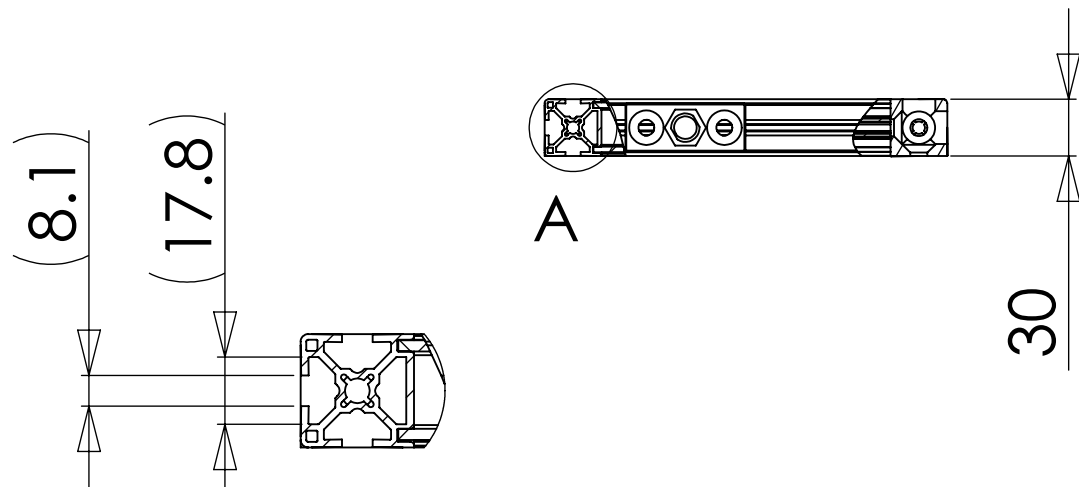

DETAIL A  
SCALE 1 : 2

**PROPRIETARY AND CONFIDENTIAL**  
 THE INFORMATION CONTAINED IN THIS DRAWING IS THE SOLE PROPERTY OF SmartVisionLights. ANY REPRODUCTION IN PART OR AS A WHOLE WITHOUT THE WRITTEN PERMISSION OF SmartVisionLights IS PROHIBITED.

UNLESS OTHERWISE SPECIFIED:		DATE	NAME	SOBL-150x350
DIMENSIONS ARE IN MM		DRAWN BY	3/19/2010	SmartVisionLights.Com
TOLERANCES:		CHECKED		matt@smartvisionlights.com
FRACTIONAL $\pm$ 1-64		ENG APPR.		
ANGULAR: MACH $\pm$ .25° BEND $\pm$ 3°		MFG APPR.		
TWO PLACE DECIMAL $\pm$ .10 mm		Q.A.		
THREE PLACE DECIMAL $\pm$ .01 mm		COMMENTS:		
INTERPRET GEOMETRIC TOLERANCING PER:				
MATERIAL				
NEXT ASSY	USED ON			
FINISH				
APPLICATION				